



# Bedder Roller

12 Row 38" Centers

1125 Series

7/19/2016



ITEM NO.	PART NUMBER	DESCRIPTION	Default/QTY.
1	MFG030748	Assembly, Center Mainframe	1
2	MFG030747L	Assembly, Roller LH Wing	1
3	MFG030747R	Assembly, Roller RH Wing	1
4	MFG030763	Assembly, 104.5" Scraper	2
5	5BRGNANF211-35R3	Bearing, Roller	8
6	MFG030760	Assembly, 104.5 Roller	2
7	MFG030761	Assembly, 116 Roller	2
8	MFG030731	Shaft, Replaceable Roller	8
9	MFG030753	Assembly, Straight Plow	20
10	MFG030712	Assembly, Roller Shank Bracket	1
11	MFG030751	Assembly, Left 7" Offset Shank	1
12	MFG030504	Bracket, SMV	1
13	1475	Cylinder, 4x16	2
14	4743	Link, 26" Adjustment lift	2
15	MFG030743	Assembly, Roller Lift Arm	2
16	MFG030754	Assembly, Left Outer Row Plow	2
17	MFG030755	Assembly, Right Outer Row Plow	2
18	MFG030752	Assembly, Right 7" Offset Shank	1
19	MFG030744	Assembly, Roller Center Shank Bracket	1
20	MFG030764	Assembly, 116" Scraper	2
21	5FEQSMV-GM	Sign, Slow Moving Vehicle	1
22	4598	Bracket, T Mount	1
23	8531	U-Bolt, 3/4 7x4	4
24	9423	Elbow, 90 Degree	4
25	5FEQ6WETX-WLN-S	Elbow, 3/8" Bulkhead	4
26	5HOS9678	Hose, 96-7/8"	1
27	5HOS9012	Hose, 90-1/2"	1
28	5HOS102	Hose, 102"	1
29	5HOS9414	HOSE, 94-1/4"	1
30	MFG030823	Pin, CAT4	1
31	MFG030879	Pin, Hitch CAT3	2
32	MFG030822	Pin, Top Hitch CAT3	1
33	9659	Hose, 60"	4
34	MFG030737	Assembly, Roller Stand	4
35	1626	Pin, Handle-Loc Hitch	4
36	MFG030740	Plate, Rear Wing Support Clamp	2
37	MFG030509	Assembly, Light Bracket	2
38	5FEQAGLIGHT	Light, Warning	1
39	5FEQHHC13	Pin, 1 x 3-1/2	4
40	5BLT3410HXZ	Bolt, 3/4" x 10"	12
41	5WSHLOCK34Z	Lock Washer, 3/4"	12
42	5NUT34HXZ	Nut, 3/4"	12
43	MFG030286	Bolt, 1-1/2" x 11" Folding Toolbar Hinge	4
44	0307L	Wheel, H.D. Offset Gauge LH	2
45	0307R	Wheel, H.D. Offset Gauge RH	2
46	5FEQR-7434	Holder, Shank	22
47	MFG030698	Assy, Bedder Safty Stop	2
48	MFG030689	Plate, Roller Rear Wng Otr Sup Mnt & Clamp	2



SIZE <b>A</b>	DWG. NO. Assy_Bed_Roller_Explode2	REV
	7/19/2016	SHEET 2 OF 2





SIZE	DWG. NO.	REV
<b>A</b>	Assy_Bed_Roller_Explode2	8
	7/19/2016	SHEET 1 OF 2

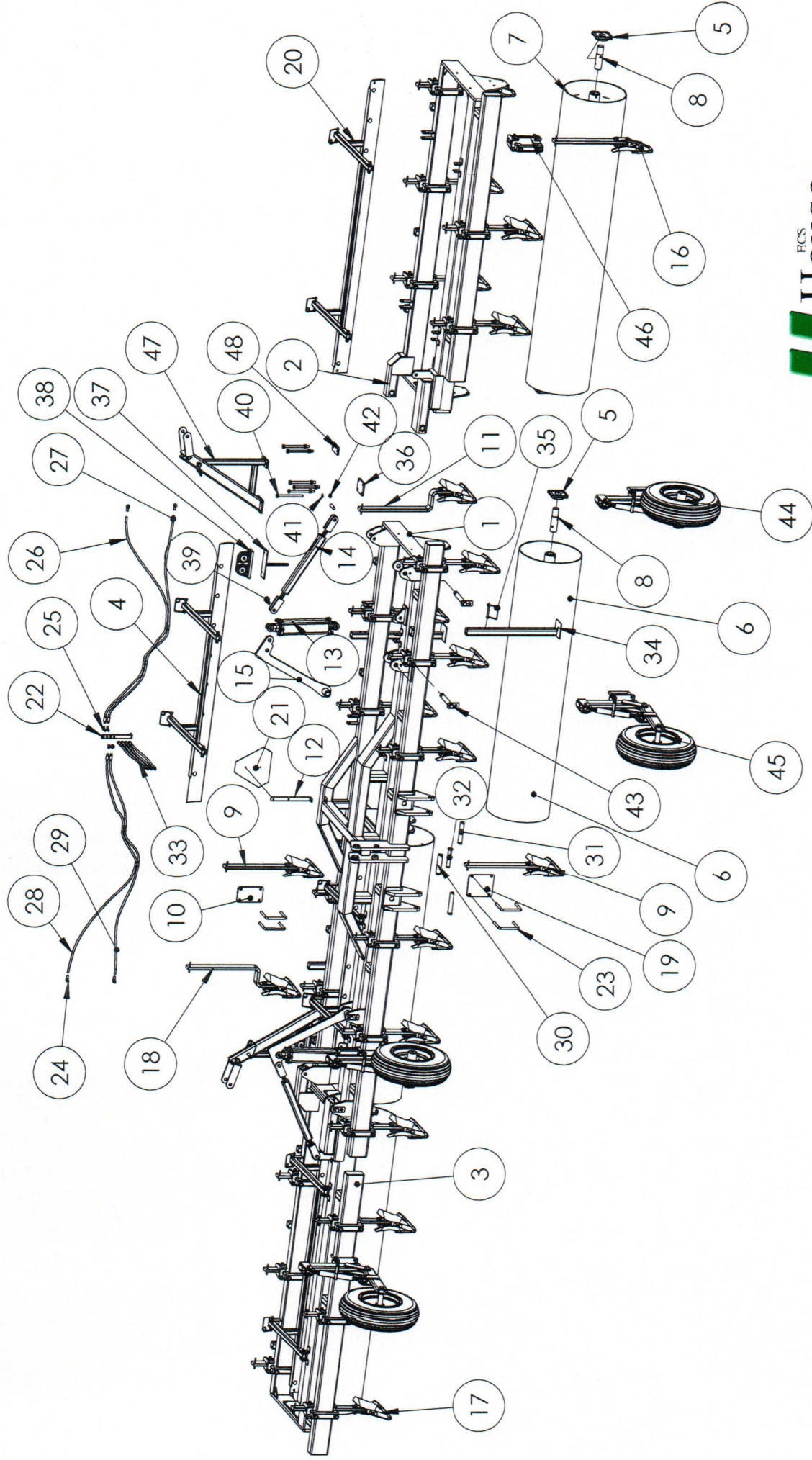

ITEM NO.	PART NUMBER	DESCRIPTION	QTY.
1	MFG030766	Assembly, 104.5" Scraper Frame	1
2	MFG030768	Blade, 104.5" Scraper	1
3	4271	Bushing, Pivot	2
4	1626	Pin, Handle-Loc Hitch	2
5	5BLT58134PLOW	Plow Bolt, 5/8	8
6	8387	Nut, 5/8	10
7	5BLT58312HXZ	Bolt, 5/8 x 3-1/2	2
8	5WSHLOCK58Z	Lock Washer, 5/8	2
9	8309	Lock, Nut 5/8	2

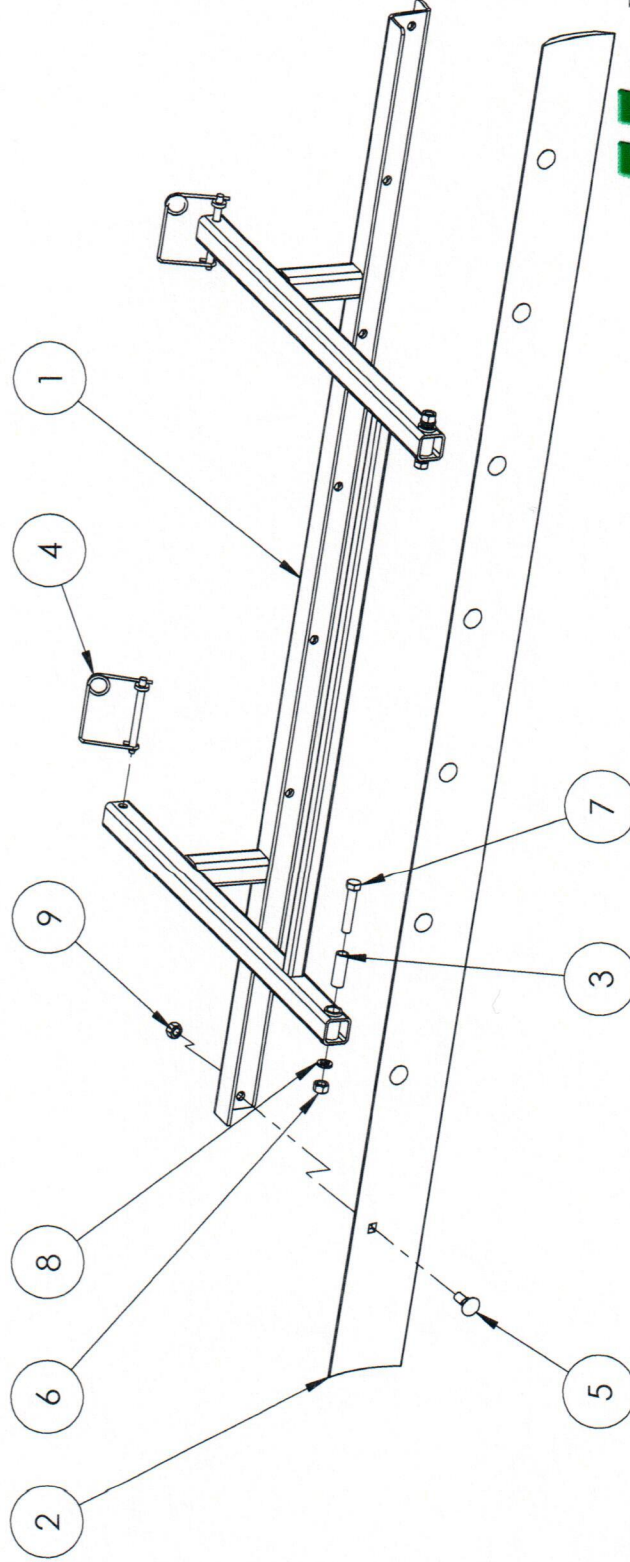

SIZE	DWG. NO.	REV
<b>A</b>	MFG030763 Explode	
	8/3/2015	SHEET 1 OF 1



ITEM NO.	PART NUMBER	DESCRIPTION	QTY.
1	MFG030767	Assembly, 116" Scraper Frame	1
2	4271	Bushing, Pivot	2
3	MFG030769	Blade, 116" Scraper	1
4	1626	Pin, Handle-Loc Hitch	2
5	Plow Bolt, 5/8 x 1-3/4	5BLT58134PLOW	10
6	8387	Nut, 5/8	10
7	5BLT58312HXZ	Bolt, 5/8 x 3-1/2	2
8	5WSHLOCK58Z	Lock Washer, 5/8	2
9	8432	Lock Nut, 5/8	2

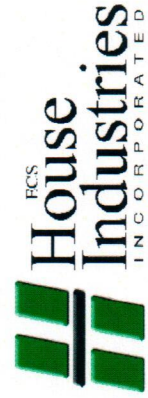
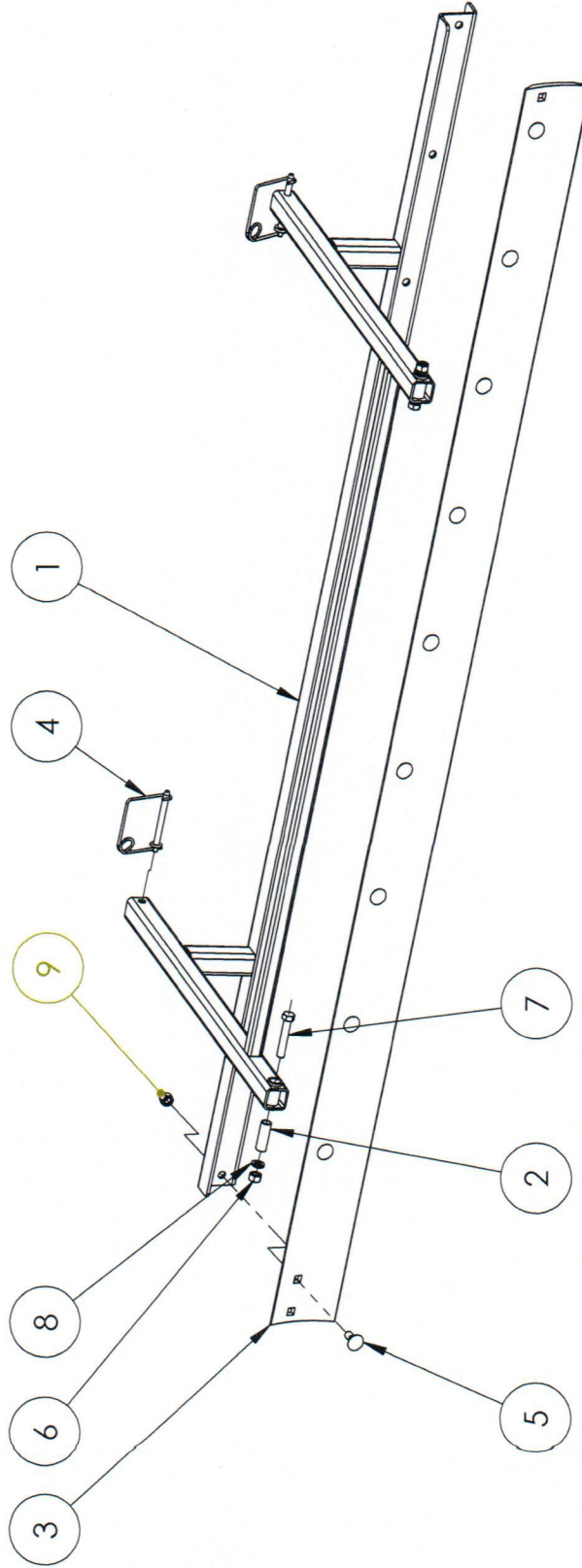

SIZE	DWG. NO.	REV
<b>A</b>	MFG030764 Explode	
	8/3/2015	SHEET 1 OF 1

ITEM NO.	PART NUMBER	DESCRIPTION	QTY.
1	SPS 0.375x4	Pin, Roll	1
2	5FEQSK-3 7 OS	Shank, 7" Offset Plow L&R	1
3	5BLT583HXZ	Bolt, 5/8 x 3	2
4	5WSHFLT58Z	Flat Washer, 5/8	4
5	5WSHLOCK58S	Lockwasher, 5/8" SS	2
6	8309	Lock Nut, 5/8"	2
7	5FEQ11NSLOTHFT	Plow, Bed	1
8	5BLT123PLOW	Plow Bolt. 1/2	1
9	5BLTCB123S	CARRIAGE BOLT, 1/2" X 3"LG SS	1
10	5FEQFP-3HDT	Foot, Plow	1
11	5FEQFPA-23	Adaptor, Plow Foot	1
12	8303	Lock Nut, 1/2"	2

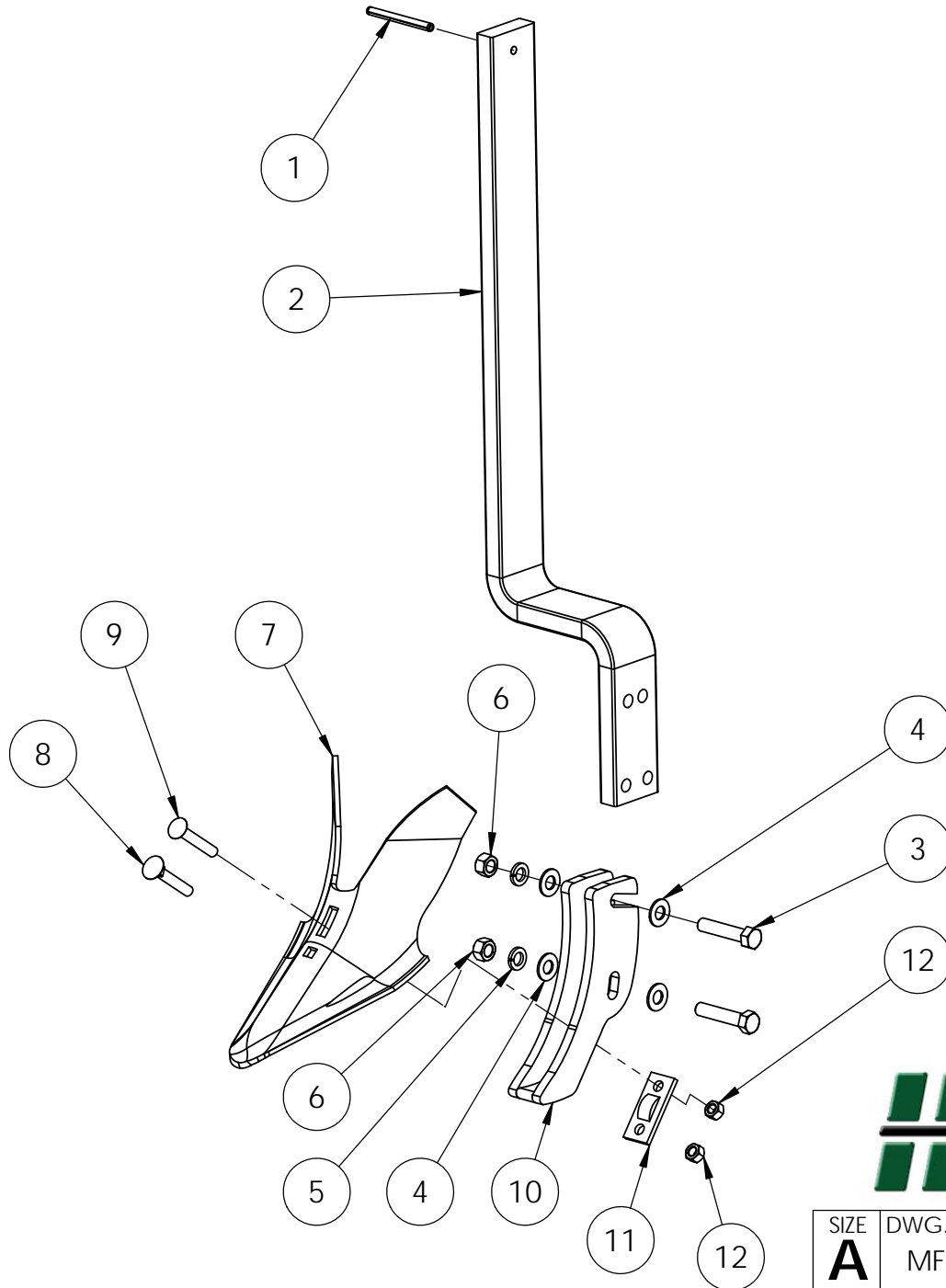

SIZE <b>A</b>	DWG. NO. MFG030751_Explode	REV
	8/5/2015	SHEET 1 OF 1

ITEM NO.	PART NUMBER	DESCRIPTION	QTY.
1	5FEQ11NSLOTHFT	Plow, Bed	1
2	5FEQFP-3HDT	Foot, Plow	1
3	5FEQSSK-3	Shank, 30" Straight Plow	1
4	5FEQFPA-23	Adaptor, Plow Foot	1
5	SPS 0.375x4	Pin, Roll	1
6	5WSHFLT58Z	Flat Washer, 5/8	4
7	5WSHLOCK58S	Lockwasher, 5/8" SS	2
8	5NUTLOCK12NCZ	Lock Nut, 1/2"	2
9	5NUTLOCK58NCZ	Lock Nut, 5/8"	2
10	5BLT123PLOW	Plow Bolt. 1/2	1
11	5BLTCB123S	CARRIAGE BOLT, 1/2" X 3"LG SS	1
12	5BLT583HXZ	Bolt, 5/8 x 3	2

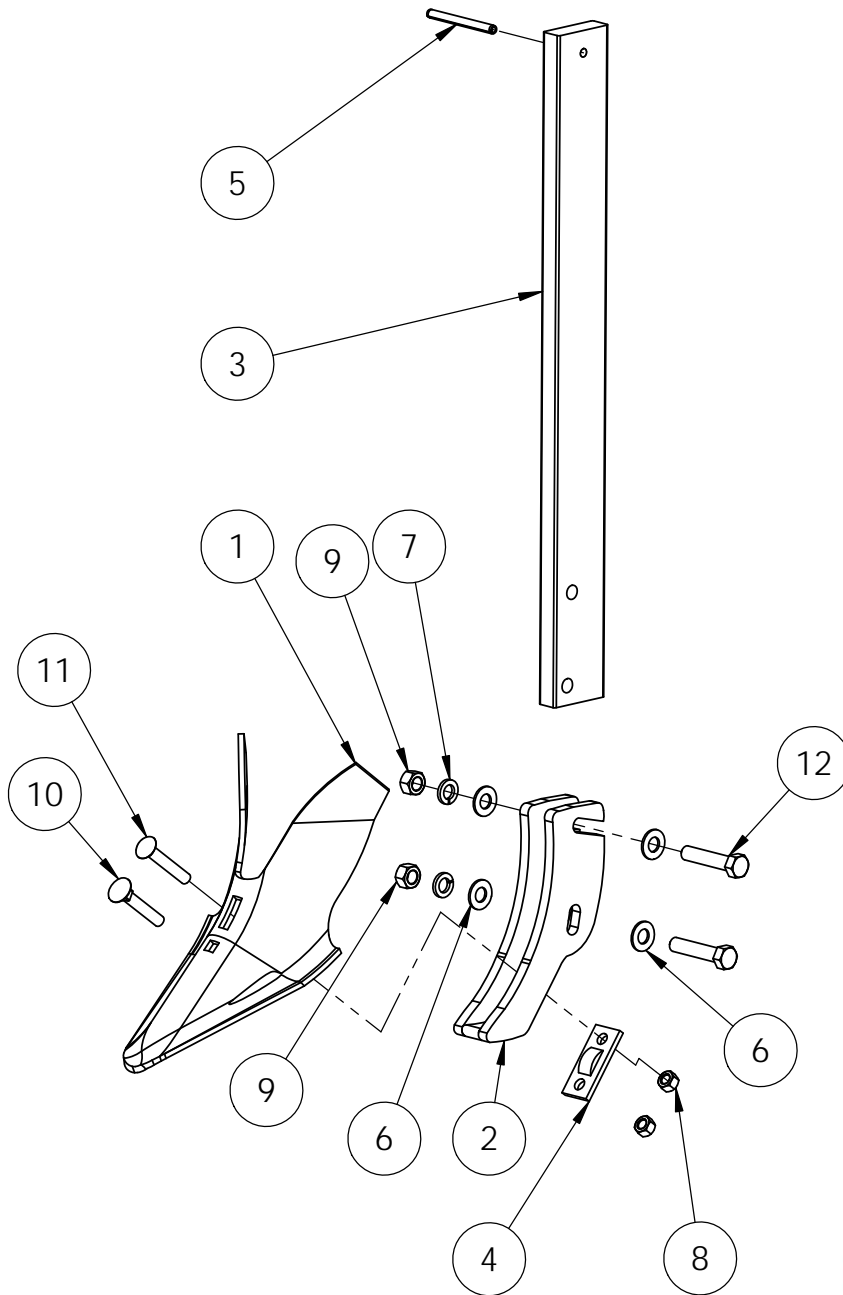

SIZE <b>A</b>	DWG. NO. MFG030753_Explode	REV
	8/5/2015	SHEET 1 OF 1

ITEM NO.	PART NUMBER	DESCRIPTION	QTY.
1	MFG030749R	Plow, Bed RH	1
2	5BLT123Plow	Plow Bolt, 1/2" X 3"	1
3	5NUTLOCK12NCZ	Center- Lock Nut, 1/2"	2
4	5WSHLOCK58Z	Lock Washer, 5/8"	2
5	5WSHFLT58Z	Flat Washer, 5/8"	4
6	5NUTLOCK58NCZ	Lock Nut, 5/8"	2
7	5BLT583HXZ	Bolt, 5/8" x 3"	2
8	5PIN384	Pin, Roll	1
9	5FEQFPA-23	Adaptor, Plow Foot	1
10	5FEQSSK-3	Shank, 30" Straight Plow	1
11	5FEQFP-3HDT	Foot, Plow	1
12	5BLTCB123ZG5	Carriage Bolt, 1/2" X 3"	1
*	MFG030749L	Plow, Bed LH	

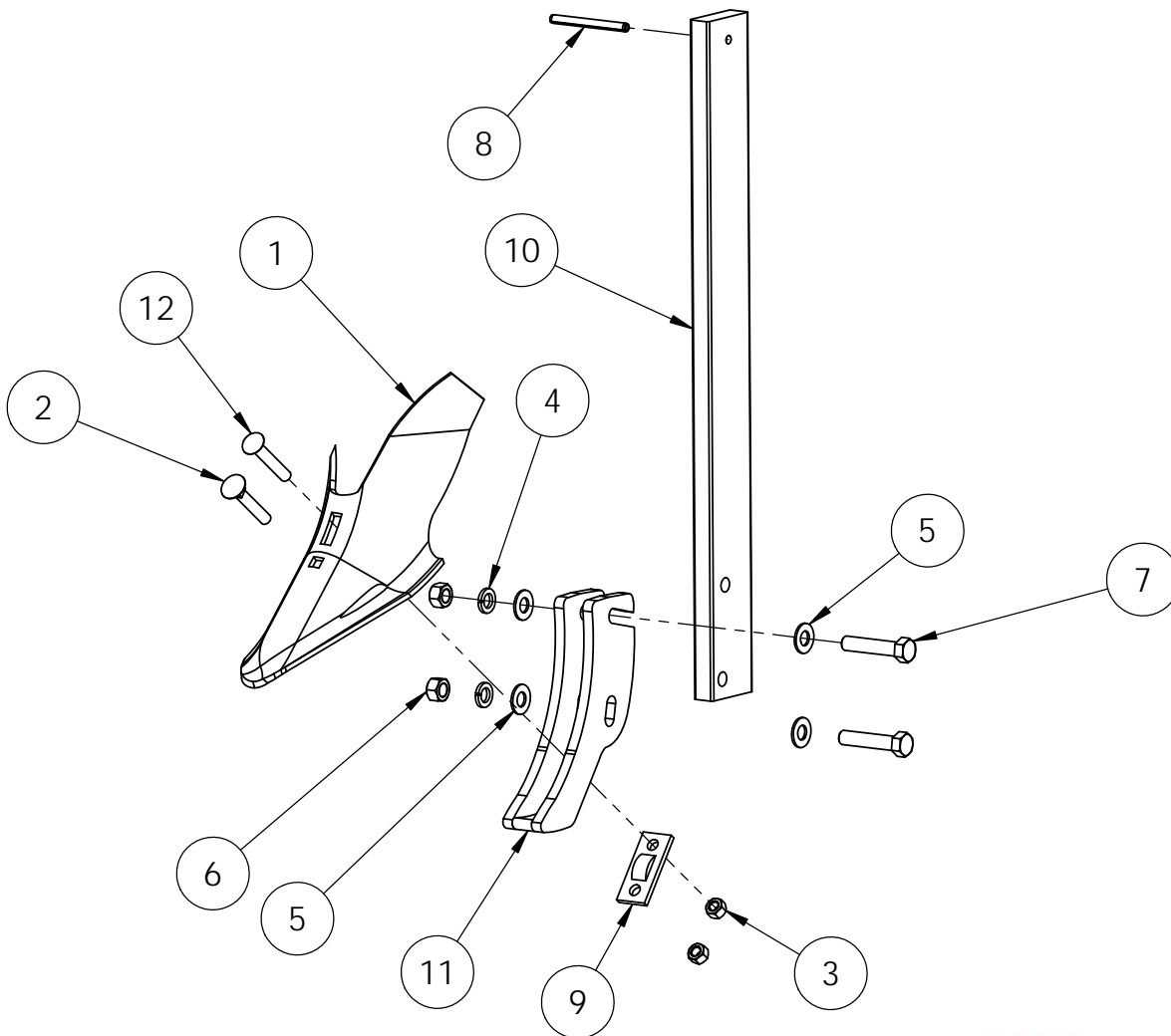

SIZE <b>A</b>	DWG. NO. MFG030754_Explode	REV
	8/5/2015	SHEET 1 OF 1



ITEM NO.	PART NUMBER	DESCRIPTION	QTY.
1	5WHL9.5L15X8X5	Assembly, Tire-Wheel 9.5L15 x 8, 5 Hole	1
2	8531	U-Bolt, 3/4 7x4	2
3	8450	Jack, Turnbuckle	1
4	2741	Bracket, Offset Ga Wheel RH	1
*	2742	Bracket, Offset Ga Wheel LH	
6	4507	Bracket, HD Ga Wheel	1
7	5NUT34HXZ	Nut, 3/4"	4
8	5WSHLOCK34Z	Lock Washer, 3/4"	4
9	5FEQHC14	Pin, 1 x 3-7/8	2
10	5BLT1412HXZ	Bolt, 1" X 4-1/2"	1
11	9032	Hub, Ga Wheel	1
12	5WSHLOCK1Z	Lockwasher, 1" GR 8 Zinc	1
13	5NUT1HXZ	Nut, 1"	1

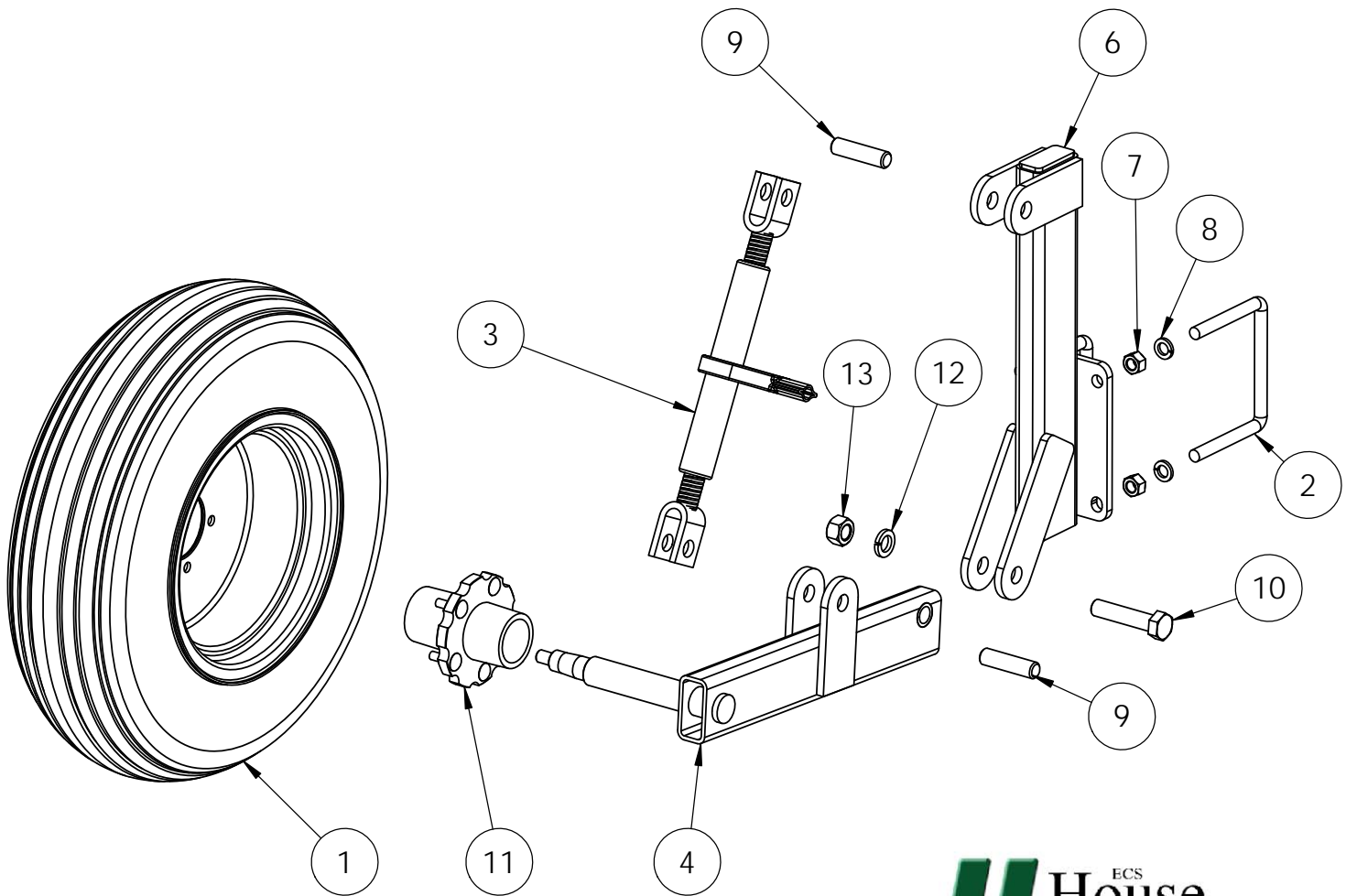

SIZE <b>A</b>	DWG. NO. 0307R_Explode	REV
	7/19/2016	SHEET 1 OF 1