



302-BEDDER-CHOPPER-1230

12 Row 30" Centers

302 Series

Parts List And Drawings

5/17/2019

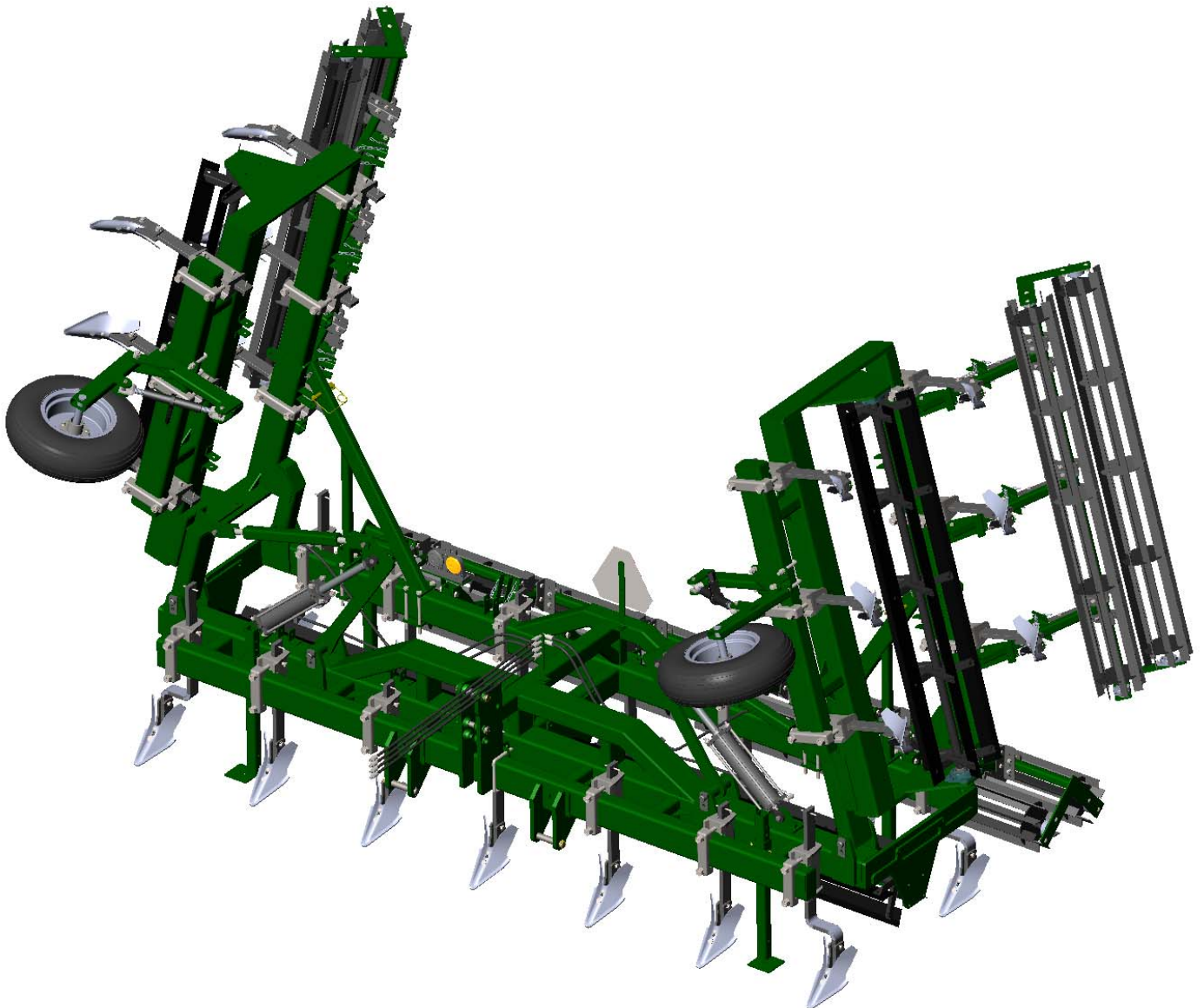

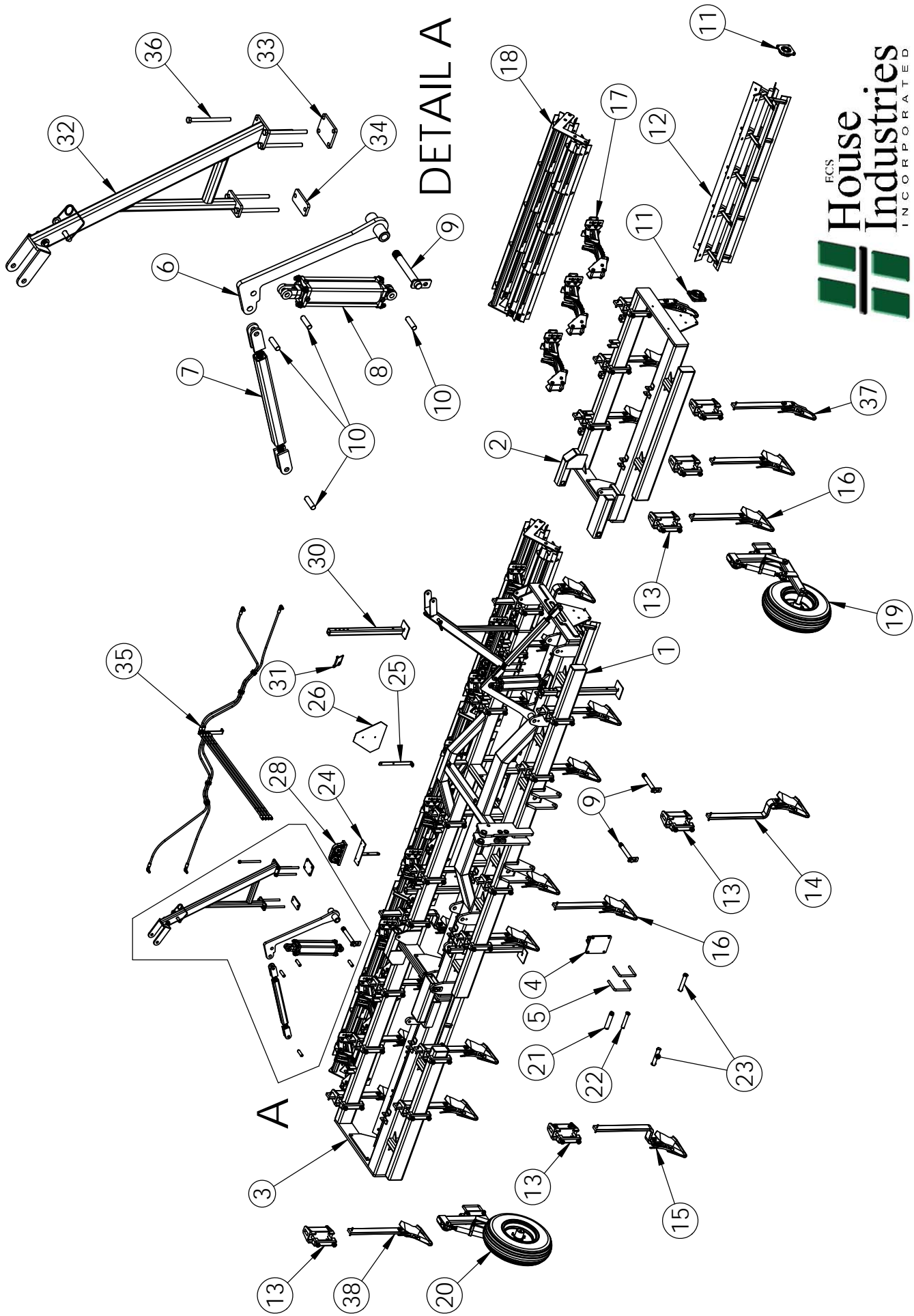

SIZE	DWG. NO.	REV
A	302-Bedder-Chopper-1230	
	5/17/2019	SHEET 1 OF 2

ITEM NO.	PART NUMBER	DESCRIPTION	QTY.
1	MFG030787	Assembly, 30' Center Bar Mainframe Welded	1
2	MFG030786L	Assembly, 30' Roller LH Wing Welded Frame	1
3	MFG030786R	Assembly, 30' Roller RH Wing Welded Frame	1
4	MFG030744	Assembly, Roller Center Shank Bracket	2
5	8531	U-Bolt, 3/4 7x4	2
6	MFG030743	Assembly, Roller Lift Arm	2
7	4743	Link, 26" Adjustment lift	2
8	1475	Cylinder, 4x16	2
9	MFG030286	Bolt, 1-1/2" x 11" Folding Toolbar Hinge	4
10	5FEQHC13	Pin, 1 x 3-1/2	8
11	5BRGNANF211-32R3	Bearing, 2" 4 Bolt	8
12	MFG031026	Assy, 88" Chopper W/ Blades	4
13	5FEQR-7434	Holder, Shank	24
14	MFG030751	Assembly, Left 7" Offset Shank	2
15	MFG030752	Assembly, Right 7" Offset Shank	2
16	MFG030753	Assembly, Straight Plow	18
17	4900	Assembly, 31" Basket Linkage Arm Complete	12
18	1995	Assembly, 93" Spiral Bar Basket	4
19	0307R	Wheel, H.D. Offset Gauge RH	1
20	0307L	Wheel, H.D. Offset Gauge LH	1
21	MFG030823	Pin, CAT4	1
22	MFG030822	Pin, Top Hitch CAT3	1
23	MFG030879	Pin, Hitch CAT3	2
24	MFG030509	Assembly, Light Bracket	2
25	MFG030504	Bracket, SMV	1
26	5FEQSMV-GM	Sign, Slow Moving Vehicle	1
27	5FEQAGLIGHT	Light, Warning	1
28	5FEQAGLIGHT	Light, Warning	1
29	MFG030737L	Assembly, Roller Stand LH	2
30	MFG030737R	Assembly, Roller Stand RH	2
31	1626	Pin, Handle-Loc Hitch	4
32	MFG030682	Assy, Bedder Safty Stop	2
33	MFG030740	Plate, Rear Wing Support Clamp	2
34	MFG030689	Plate, Roller Rear Wng Otr Sup Mnt & Clamp	2
35	MFG033016	Kit. 30' Bedder Hose	1
36	5BLT3410HXZ	Bolt, 3/4" x 10"	12
37	MFG030754	Assembly, Left Outer Row Plow	2
38	MFG030755	Assembly, Right Outer Row Plow	2



SIZE A	DWG. NO. 302-Bedder-Chopper-1230	REV
5/17/2019		SHEET 2 OF 2

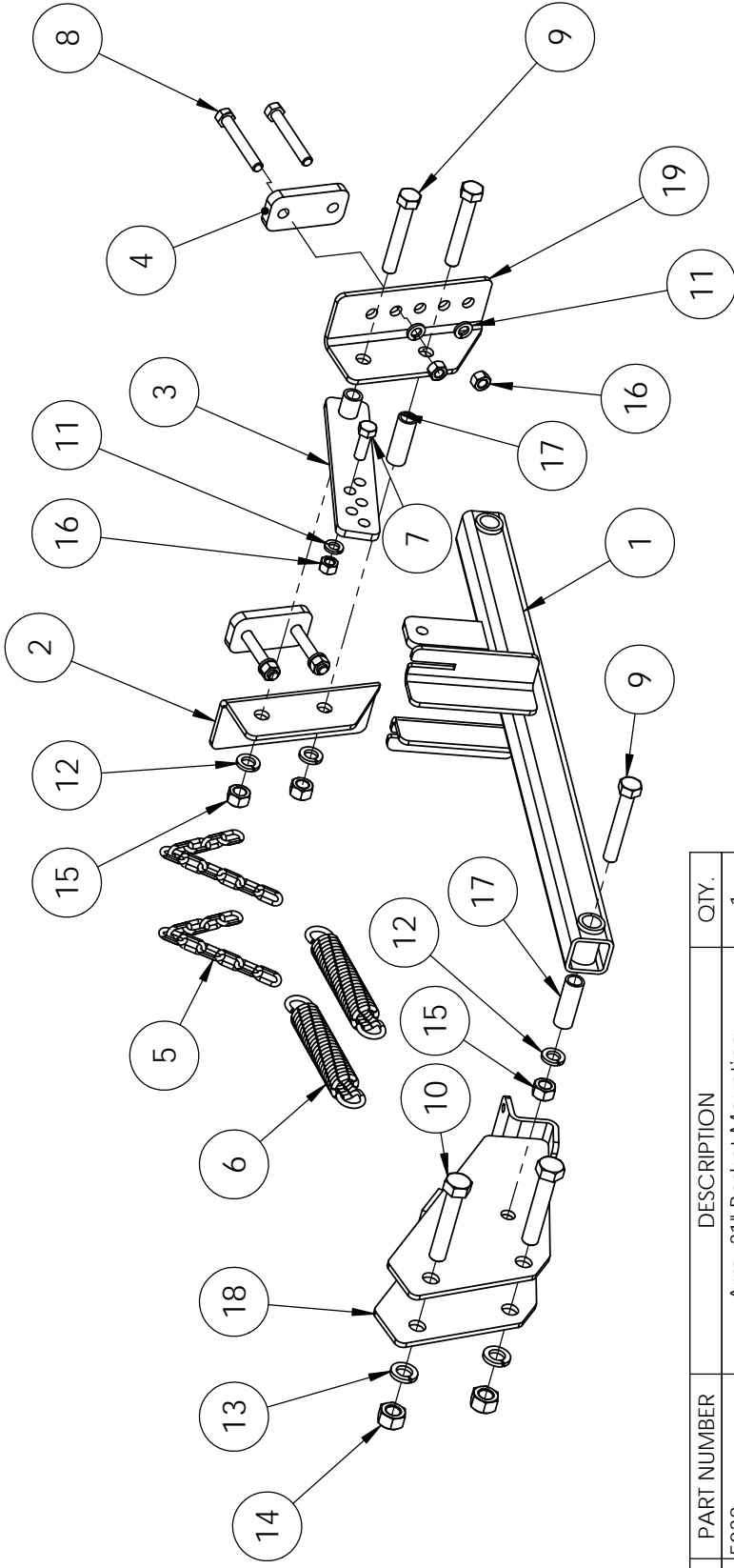

ITEM NO.	PART NUMBER	DESCRIPTION	QTY.
1	5038	Arm, 31" Basket Mounting	1
2	4573L	Angle, LH Basket Frame Attachment	1
3	1939	Link, Basket Adjustment	1
4	4396	Clamp, Basket Linkage	2
5	4335	Chain 3/16" 10 Links Long	2
6	4336	Spring, Basket Linkage	2
7	5BLT12112HXZ	Bolt, 1/2" X 1-1/2"	1
8	5BLT12312HXZ	Bolt, 1/2" X 3/12"	4
9	5BLT584HXZ	Bolt, 5/8" X 4"	3
10	5BLT344HXZ	Bolt, 3/4" X 4"	2
11	5WSHLOCK12Z	Lock Washer, 1/2"	5
12	5WSHLOCK58Z	Lock Washer, 5/8"	3
13	5WSHLOCK34Z	Lock Washer, 3/4"	2
14	5NUT34HXZ	Nut, 3/4"	2
15	5NUT58HXZ	Nut, 5/8"	3
16	5NUT12HXZ	Nut, 1/2"	5
17	4271	Bushing, Basket Arm Pivot	2
18	4571	Mount, Basket Arm	1
19	4573R	Angle, RH Basket Frame Attachment	1



SIZE	DWG. NO.	REV
A	4900_Explode	
	8/3/2015	SHEET 1 OF 1

ITEM NO.	PART NUMBER	DESCRIPTION	QTY.
1	1968	Frame, 93" Basket	1
2	4356	Bearing, Flange	4
3	5BLTCB12114Z	Carriage Bolt, 1/2 x 1-1/2	8
4	5NUTLOCK12NCZ	1/2" -13 Center- Lock Nut N/C Zinc	8
5	1987	Assembly, 93" Spiral Basket	2

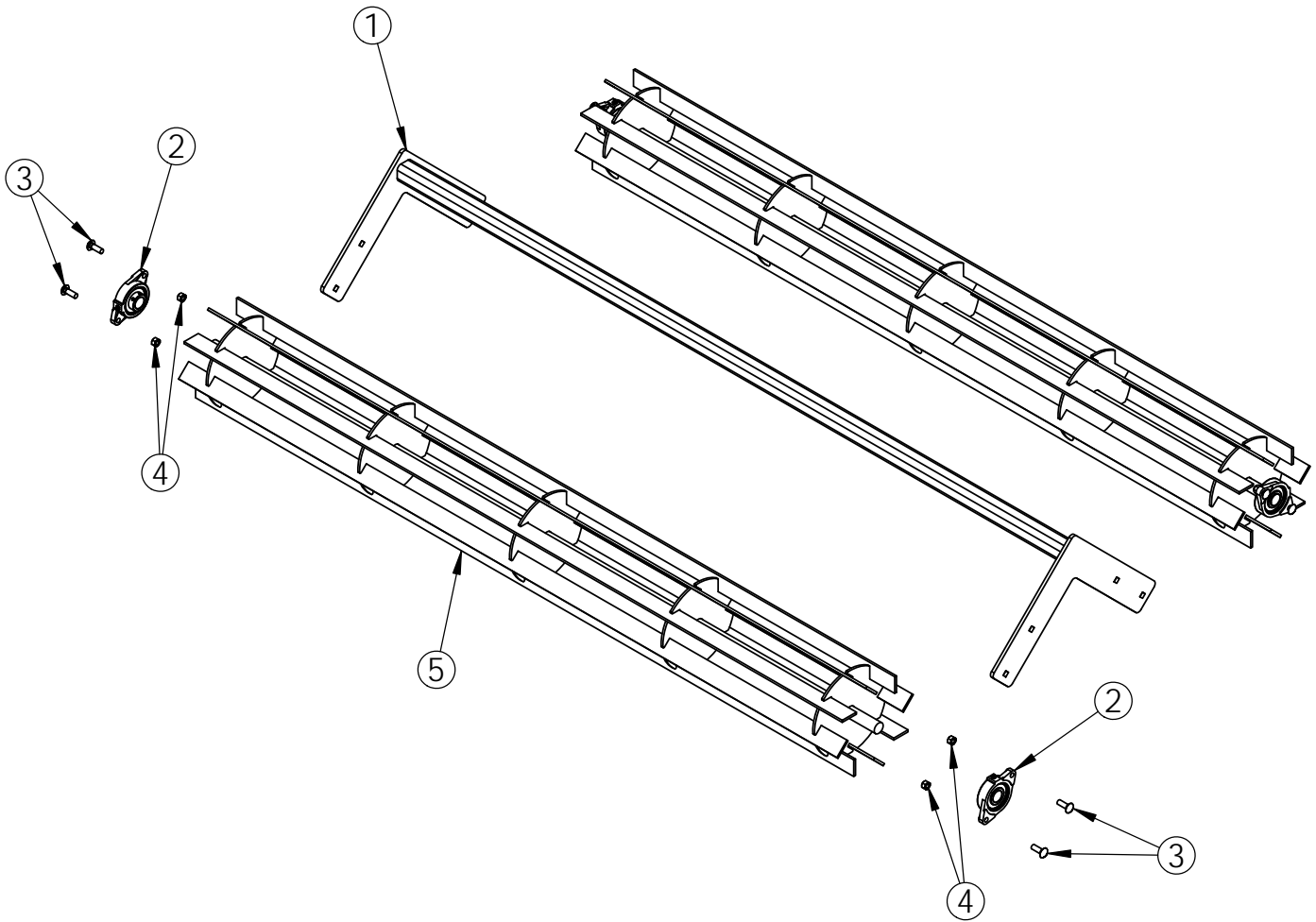

93" SPIRAL BAR BASKET ASSEMBLY



SIZE A	DWG. NO. 1995	REV
	5/9/2019	SHEET 1 OF 1

ITEM NO.	PART NUMBER	DESCRIPTION	QTY.
1	MFG031025	Assy, 88" Chopper Welded	1
2	3817	88" 5 Hole Spiral Blade w/ Straight Ends	5

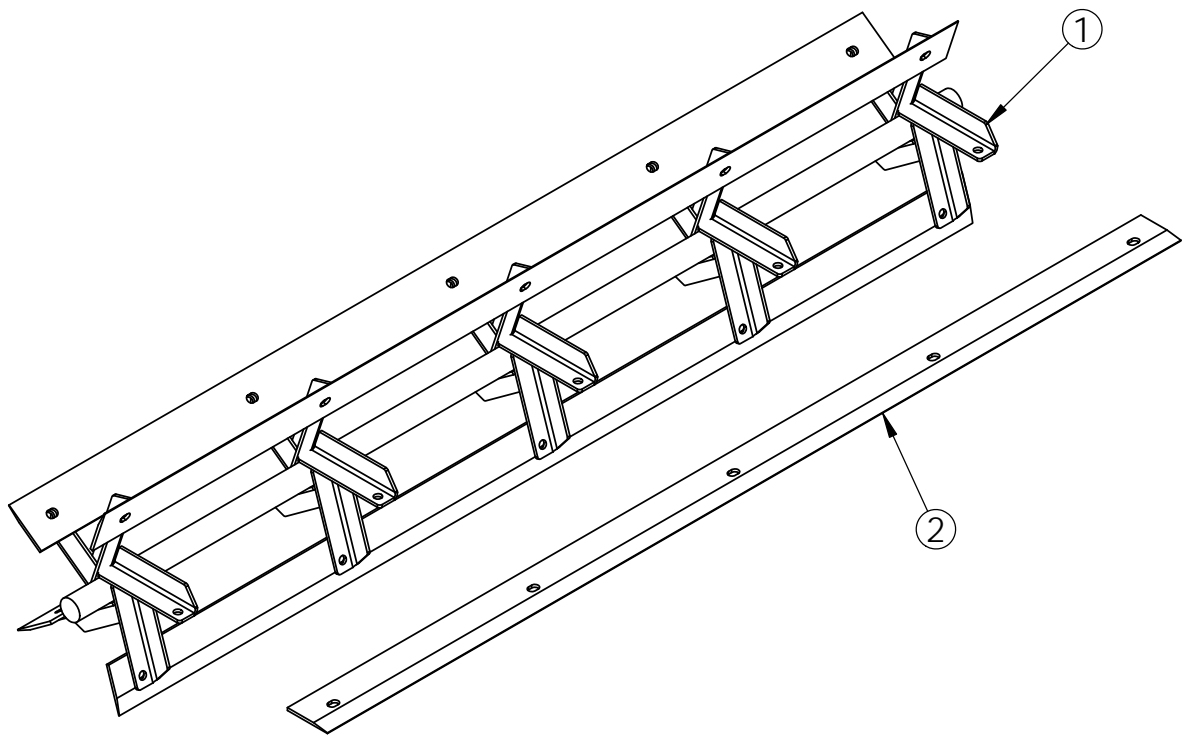

88" CHOPPER ASSY W/ BLADES



SIZE A	DWG. NO. MFG031026	REV
	5/20/2019	SHEET 1 OF 1

ITEM NO.	PART NUMBER	DESCRIPTION	QTY.
1	5FEQ11NSLOTHFT	Plow, Bed	1
2	5FEQFP-3HDT	Foot, Plow	1
3	5FEQSSK-3	Shank, 30" Straight Plow	1
4	5FEQFPA-23	Adaptor, Plow Foot	1
5	SPS 0.375x4	Pin, Roll	1
6	5WSHFLT58Z	Flat Washer, 5/8	4
7	5WSHLOCK58S	Lockwasher, 5/8" SS	2
8	5NUTLOCK12NCZ	Lock Nut, 1/2"	2
9	5NUTLOCK58NCZ	Lock Nut, 5/8"	2
10	5BLT123PLOW	Plow Bolt. 1/2	1
11	5BLTCB123S	CARRIAGE BOLT, 1/2" X 3"LG SS	1
12	5BLT583HXZ	Bolt, 5/8 x 3	2

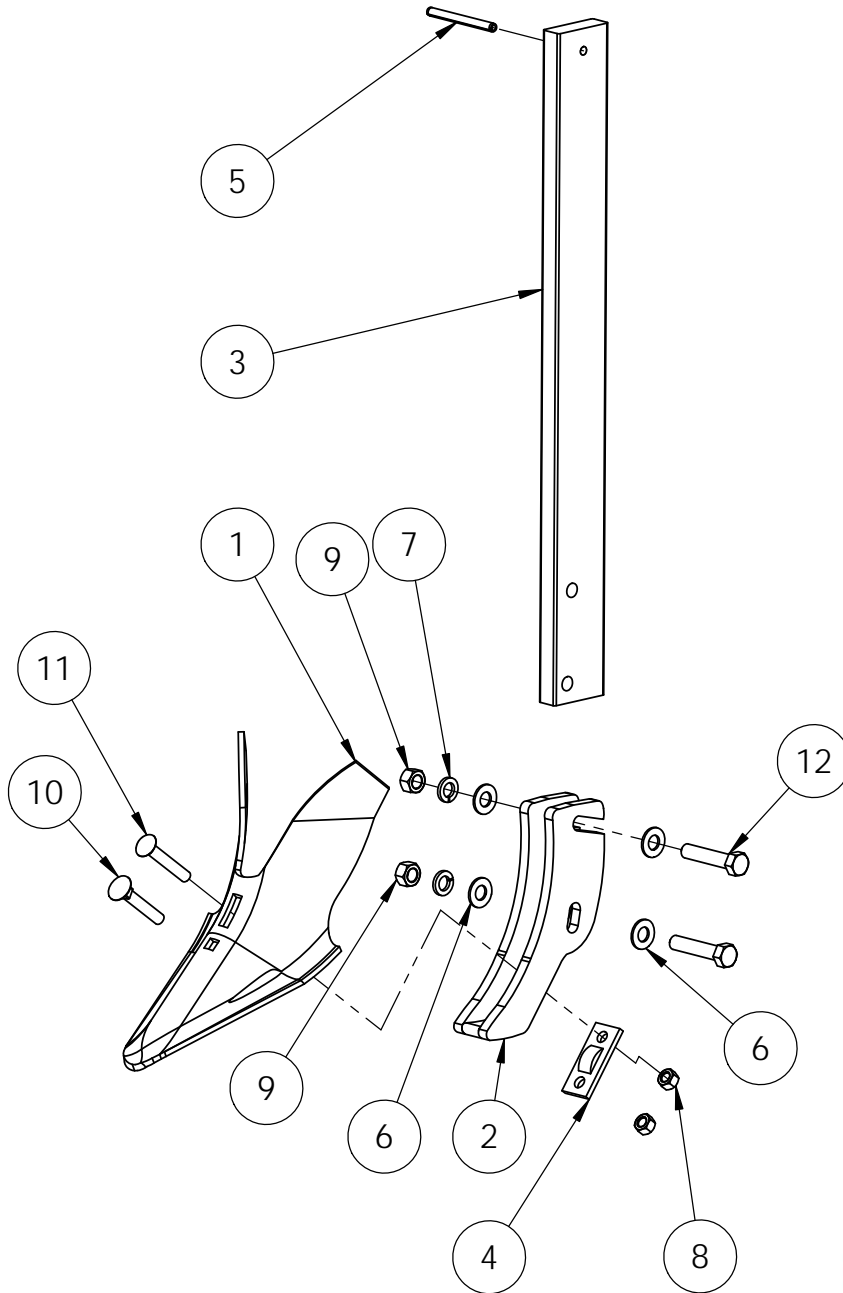

SIZE A	DWG. NO. MFG030753_Explode	REV
	8/5/2015	SHEET 1 OF 1

ITEM NO.	PART NUMBER	DESCRIPTION	QTY.
1	MFG030749R	Plow, Bed RH	1
2	5BLT123Plow	Plow Bolt, 1/2" X 3"	1
3	5NUTLOCK12NCZ	Center- Lock Nut, 1/2"	2
4	5WSHLOCK58Z	Lock Washer, 5/8"	2
5	5WSHFLT58Z	Flat Washer, 5/8"	4
6	5NUTLOCK58NCZ	Lock Nut, 5/8"	2
7	5BLT583HXZ	Bolt, 5/8" x 3"	2
8	5PIN384	Pin, Roll	1
9	5FEQFPA-23	Adaptor, Plow Foot	1
10	5FEQSSK-3	Shank, 30" Straight Plow	1
11	5FEQFP-3HDT	Foot, Plow	1
12	5BLTCB123ZG5	Carriage Bolt, 1/2" X 3"	1
*	MFG030749L	Plow, Bed LH	

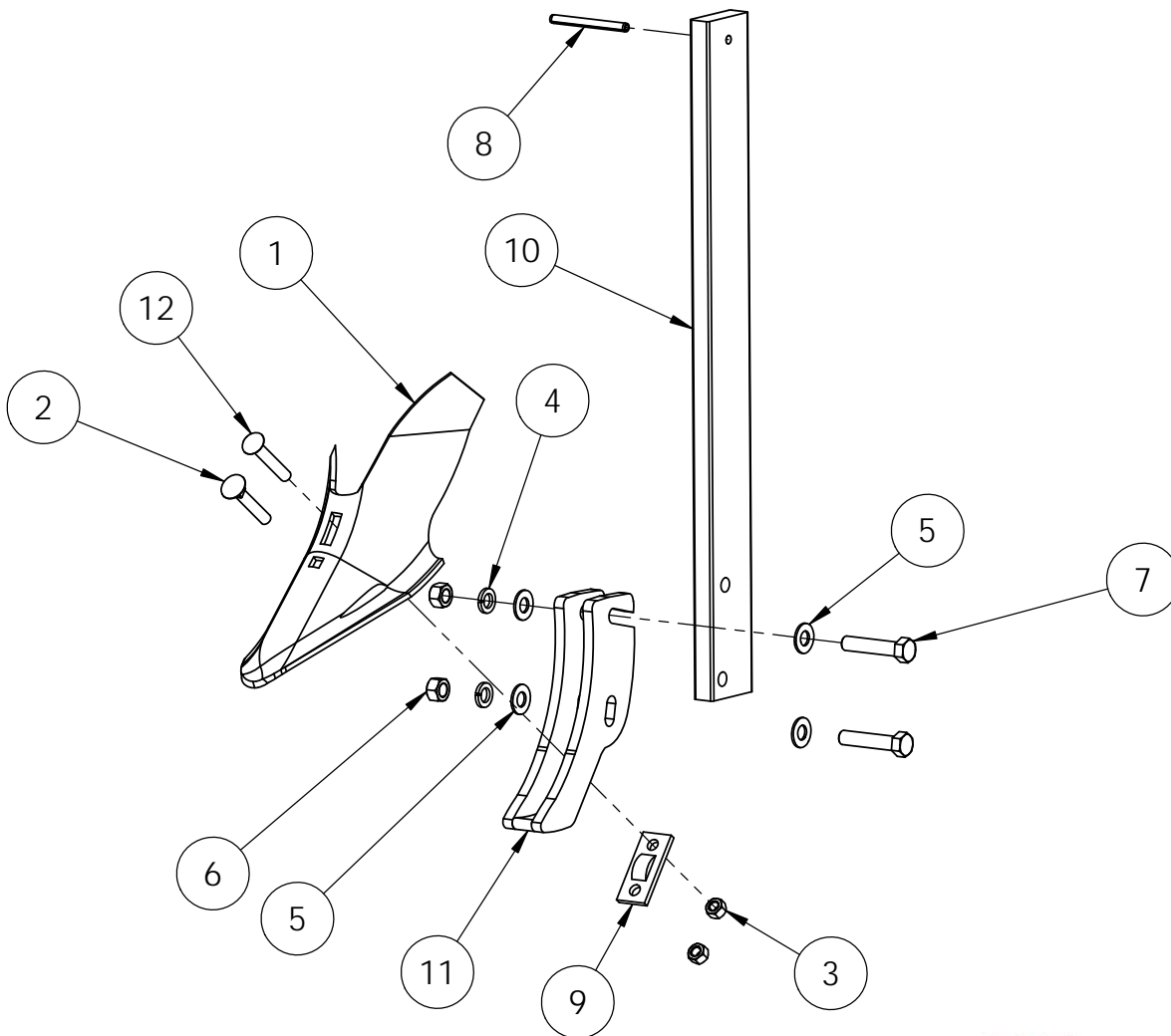

SIZE A	DWG. NO. MFG030754_Explode	REV
	8/5/2015	SHEET 1 OF 1

ITEM NO.	PART NUMBER	DESCRIPTION	QTY.
1	5PIN384	Pin, Roll	1
2	5FEQSK-3 7 OS	Shank, 7" Offset Plow L&R	1
3	5BLT583HXZ	Bolt, 5/8 x 3	2
4	5WSHFLT58Z	Flat Washer, 5/8	4
5	5WSHLOCK58S	Lockwasher, 5/8" SS	2
6	5BLT123PLOW	Plow Bolt. 1/2	1
7	5BLTCB123S	CARRIAGE BOLT, 1/2" X 3"LG SS	1
8	5FEQFP-3HDT	Foot, Plow	1
9	5FEQFPA-23	Adaptor, Plow Foot	1
10	MFG030749R	Plow, Bed RH	1
*	MFG030749L	Plow, Bed LH	
12	5NUTLOCK12NCZ	Lock Nut, 1/2"	2
13	5NUTLOCK58NCZ	Lock Nut, 5/8"	2

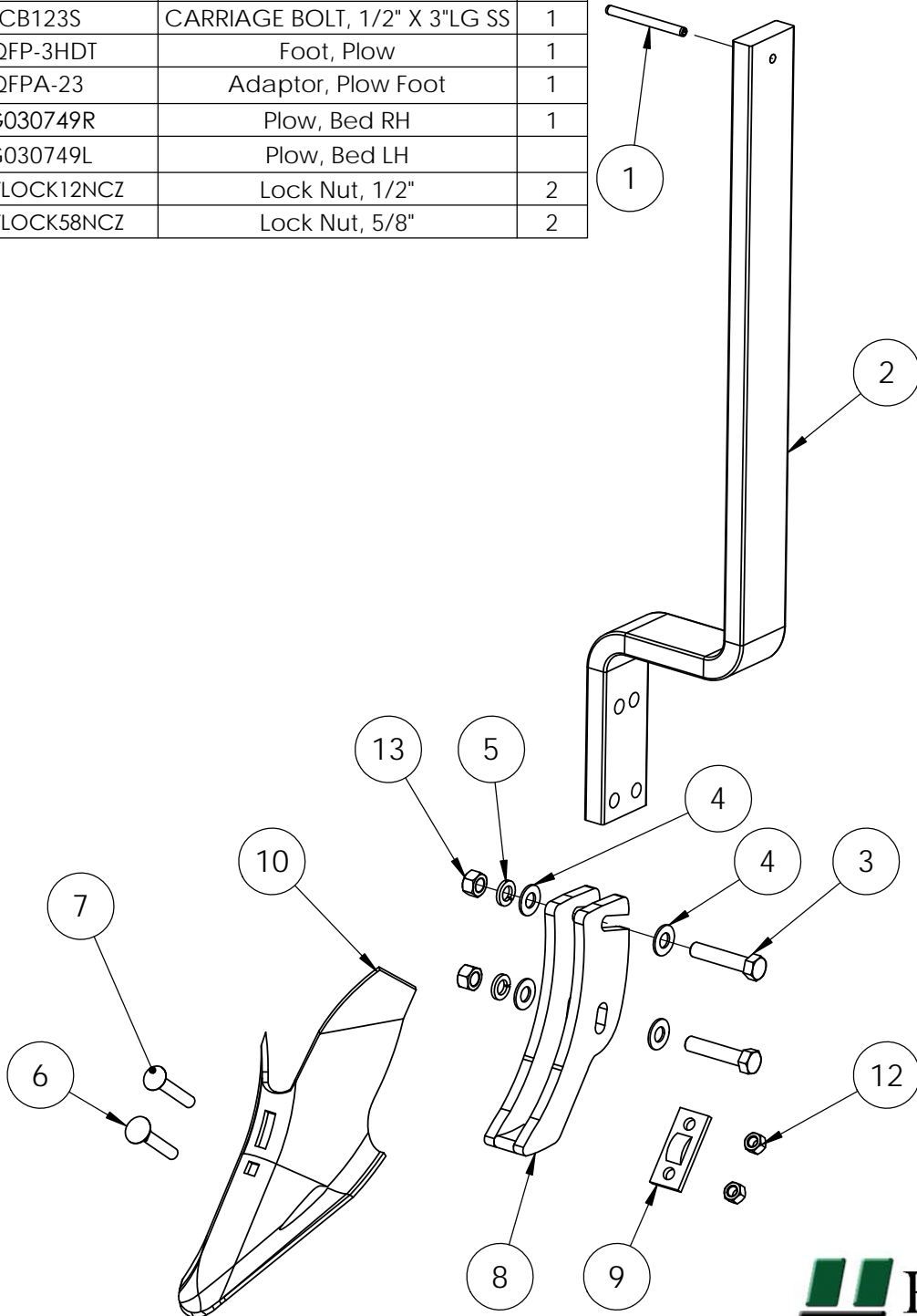

SIZE A	DWG. NO. MFG030757_Explode	REV
	7/27/2016	SHEET 1 OF 1

ITEM NO.	PART NUMBER	DESCRIPTION	QTY.
1	5WHL9.5L15X8X5	Assembly, Tire-Wheel 9.5L15 x 8, 5 Hole	1
2	8531	U-Bolt, 3/4 7x4	2
3	8450	Jack, Turnbuckle	1
4	2741	Bracket, Offset Ga Wheel RH	1
*	2742	Bracket, Offset Ga Wheel LH	
6	4507	Bracket, HD Ga Wheel	1
7	5NUT34HXZ	Nut, 3/4"	4
8	5WSHLOCK34Z	Lock Washer, 3/4"	4
9	5FEQHC14	Pin, 1 x 3-7/8	2
10	5BLT1412HXZ	Bolt, 1" X 4-1/2"	1
11	9032	Hub, Ga Wheel	1
12	5WSHLOCK1Z	Lockwasher, 1" GR 8 Zinc	1
13	5NUT1HXZ	Nut, 1"	1

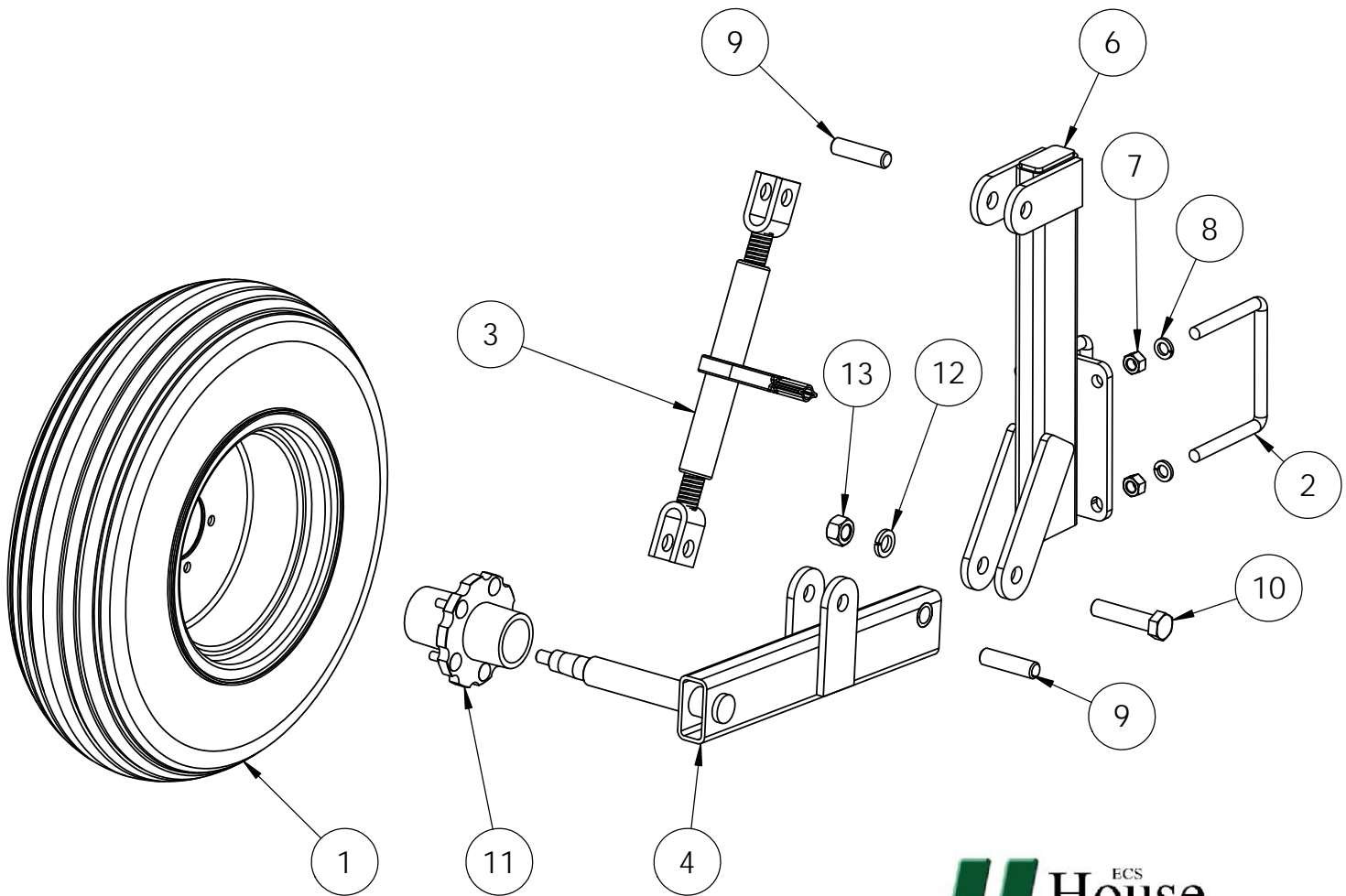

SIZE A	DWG. NO. 0307R_Explode	REV
	7/19/2016	SHEET 1 OF 1