

ECS
**House
Industries**
INCORPORATED

3PT Lift Reel Pulverizer
12 Row 36" Centers

0366F3P

Parts List & Drawings
06/04/2013

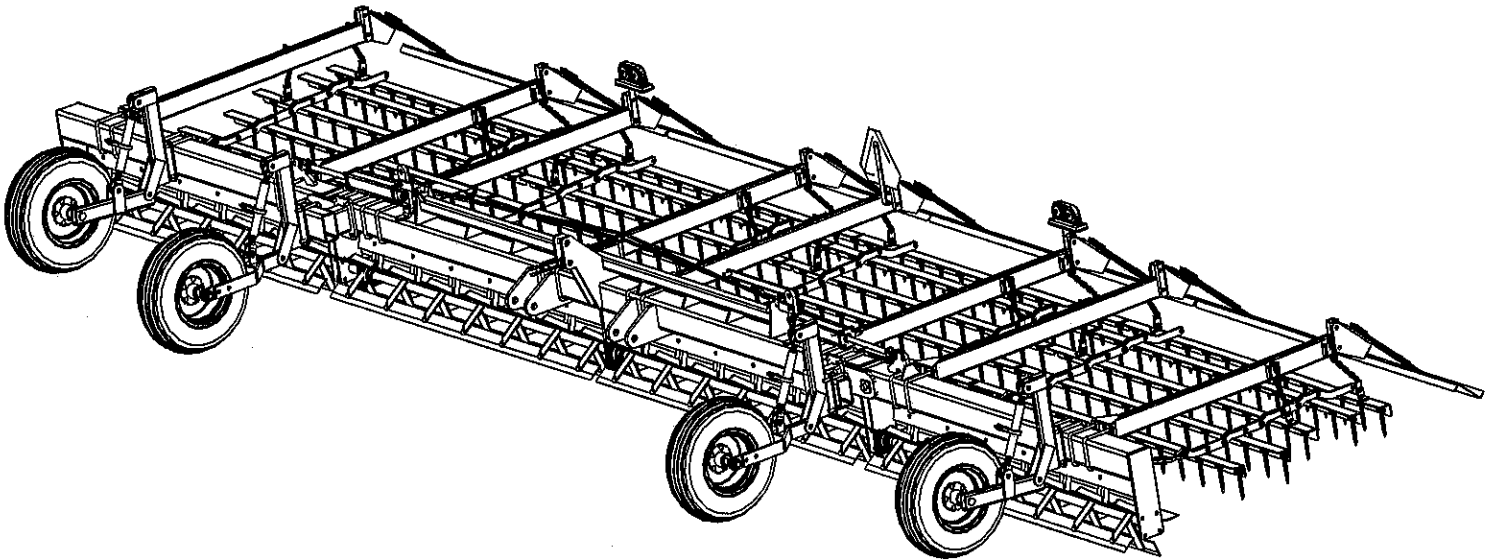

12 ROW 3PT LIFT PULVERIZER CENTER			
REF#	DESCRIPTION	QTY	PART NUMBER
1	Assembly, Pulverizer Center Bar	1	MFG030530
2	Bar, Lift Type Harrow Hanger LH	2	4491L
3	Bar, Lift Type Harrow Hanger RH	2	4491R
4	U-Bolt, 3/4" x 7" x 7" Sq.	8	8420
5	Bracket, Boardspring RH	2	4493R
6	Bracket, Boardspring LH	2	4494L
7	Plate, Dragboard Spring Reinforcement	8	2031
8	Spring, Dragboard Leaf	4	2029
9	Dragboard, 108" Metal	2	6064
10	Assy, 9' HD Flex Harrow	2	MFG030218
11	Bolt, 1 1/2" x 11" Folding Toolbar Hinge	2	2883
12	Assembly, 106 1/4" Reel	2	1950
*	Blade Only		1951
13	Bearing, Flange	4	3816
14	Cylinder 4x16	2	1475
15	Pivot, Toolbar Cylinder	2	1622
16	Link, Safty	2	1644
17	Assembly, Allthread Adjustment Clevis	2	8451
18	Pin, 1" x 3-1/4"	4	MFG030139
19	Assembly, Hydraulic Hose	1	MFG030221
20	Pin, Mast	1	3761
21	Pin, Lower Hitch	2	4809
22	Wheel, H.D. Fork Gauge w/15" wheels less tires	2	0717-1
23	Assembly, Light Bracket	2	MFG030509
24	Light, Warning	2	5FEQAGLIGHT
25	Bracket, Warning	1	MFG030504
26	Sign, Slow Moving Vehicle	1	5FEQSMV-GM

PULVERIZER CENTER BAR

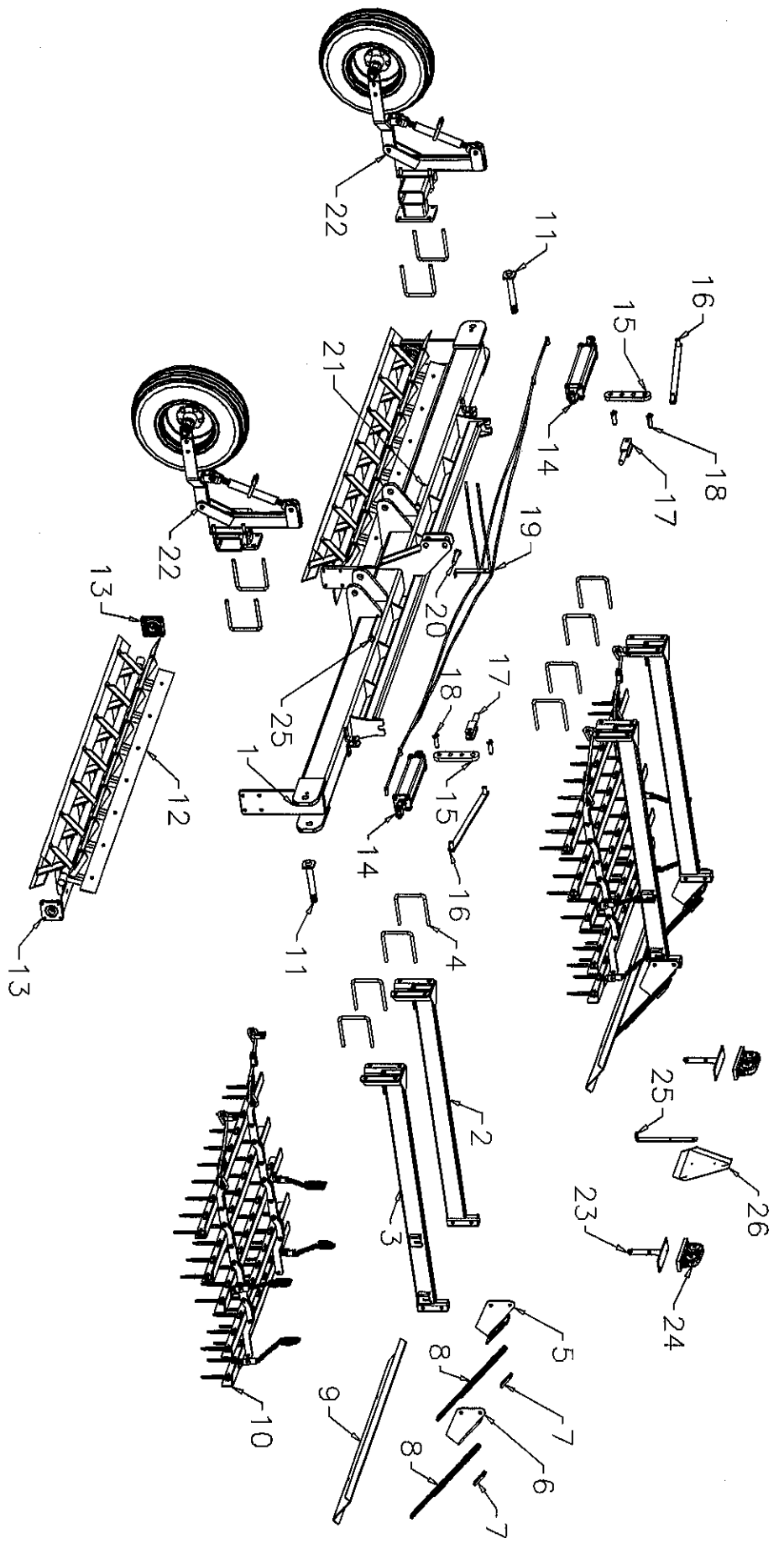

Heavy Duty Gauge Wheel		
REF#	DESCRIPTION	PART NUMBER
1	U-Bolt, 7/8" x 7" x 7" Sq.	8421
2	Bracket, L-Shank / GA Wheel Ext.	6138
3	U-Bolt, 3/4" x 7" x 4" Sq.	8531
4	Bracket,HD Gauge Wheel	4507
5	Jack, Turnbuckle	8450
6	Fork, Heavy Duty Gauge Wheel	3522
7	Plate, Gauge Wheel Fork Side	3523
8	Hub, Gauge Wheel	9080
9	Wheel, 15" x 5" - 5 Hole / Less Tire	9041

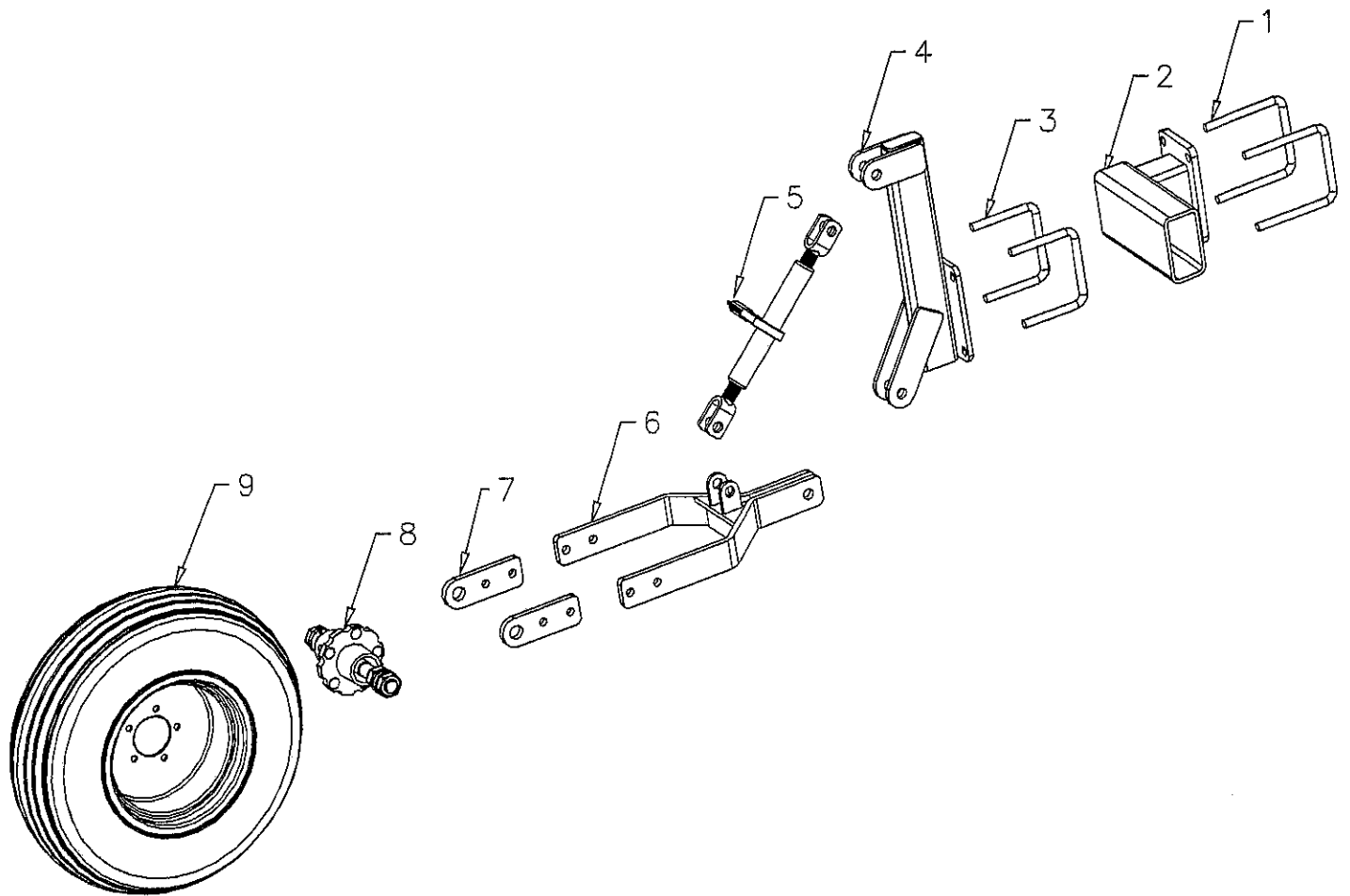

PULVERIZER WING			
REF#	DESCRIPTION	QTY	PART NUMBER
1	Assembly, Pulverizer Wing	1	MFG030220
2	Bar, Lift Type Harrow Hanger LH	1	4491L
3	Bar, Lift Type Harrow Hanger RH	1	4491R
4	U-Bolt, 3/4" x 7" x 7" Sq.	6	8420
5	Bracket, Boardspring RH	1	4493R
6	Bracket, Boardspring LH	1	4494L
7	Spring, Dragboard Leaf	2	2029
8	Plate, Dragboard Spring Reinforcement	4	2031
9	Dragboard, 112" Metal	1	MFG030085
10	Assy, 9' HD Flex Harrow	1	MFG030218
11	Bearing, Flange	2	3816
12	Assembly, 106 1/4" Reel	1	1950
*	Blade Only		1951
13	Wheel, H.D. Offset Gauge RH w/15" wheels less tires	1	0307R
*	Wheel, H.D. Offset Gauge RH w/15" wheels less tires	1	0307L

PULVERIZER WING

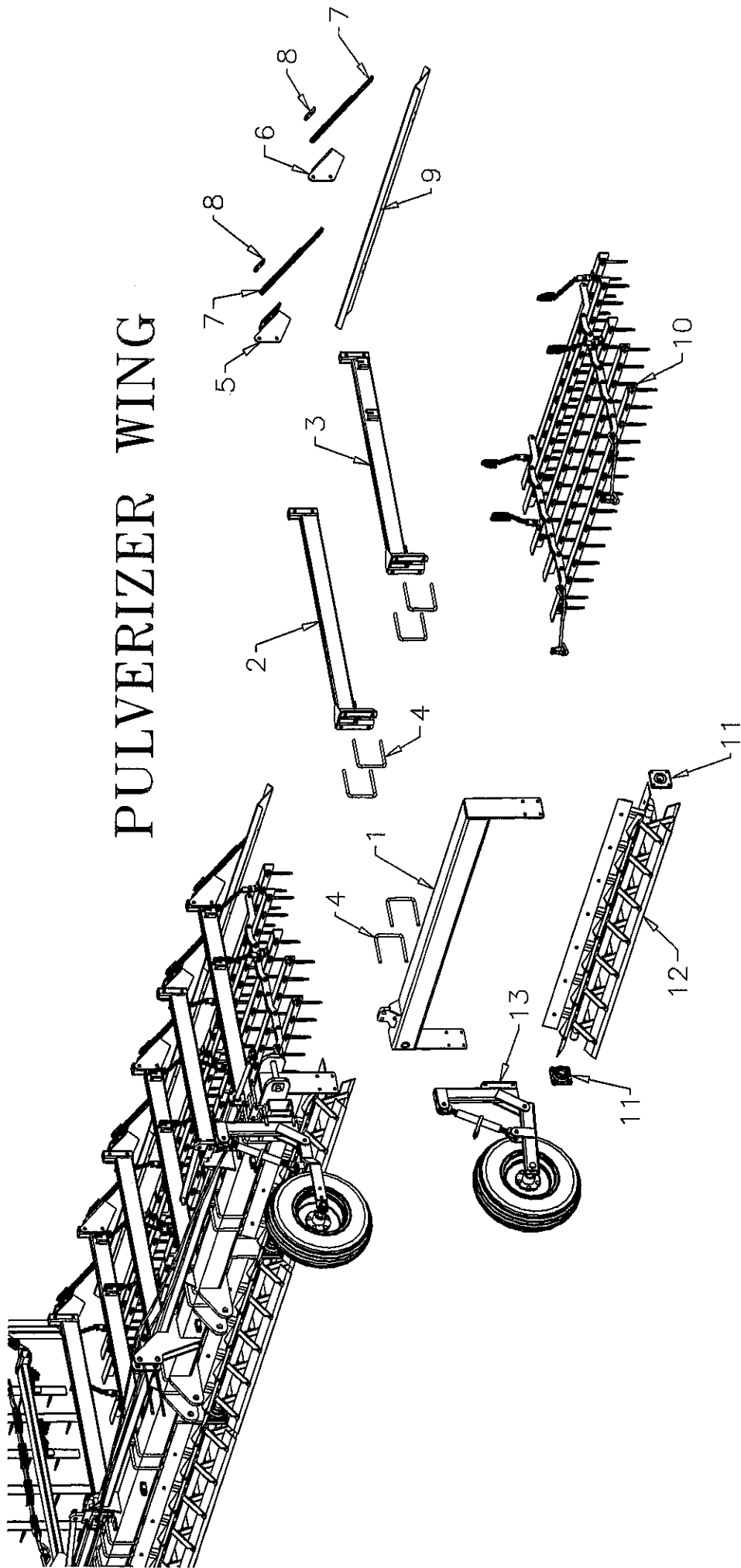

107" HARROW ASSEMBLY		
REF#	DESCRIPTION	PART NUMBER
1	Clevis, Harrow Pull	1010
2	Draglink 15"	3278
3	Link, Harrow Twisted Double Eye	1031
4	Link, Center	1028
5	Bushing, Harrow	1099
6	Chain, Harrow Lift - 21" Long	2025
7	Nut, 7/16" Center Lock N/C	8302
8	Pad, Harrow Tooth	1025
9	U-Bolt 7/16"	1026
10	Tooth, Harrow	1024
11	Pin, Lock	2724
12	Bar, #1-10 Tooth Harrow	MFG030237
13	Bar, #2-9 Tooth Harrow	MFG030238
14	Bar, #3-9 Tooth Harrow	MFG030239
15	Bar, #4-9 Tooth Harrow	MFG030240
16	Bar, #5-10 Tooth Harrow	MFG030241

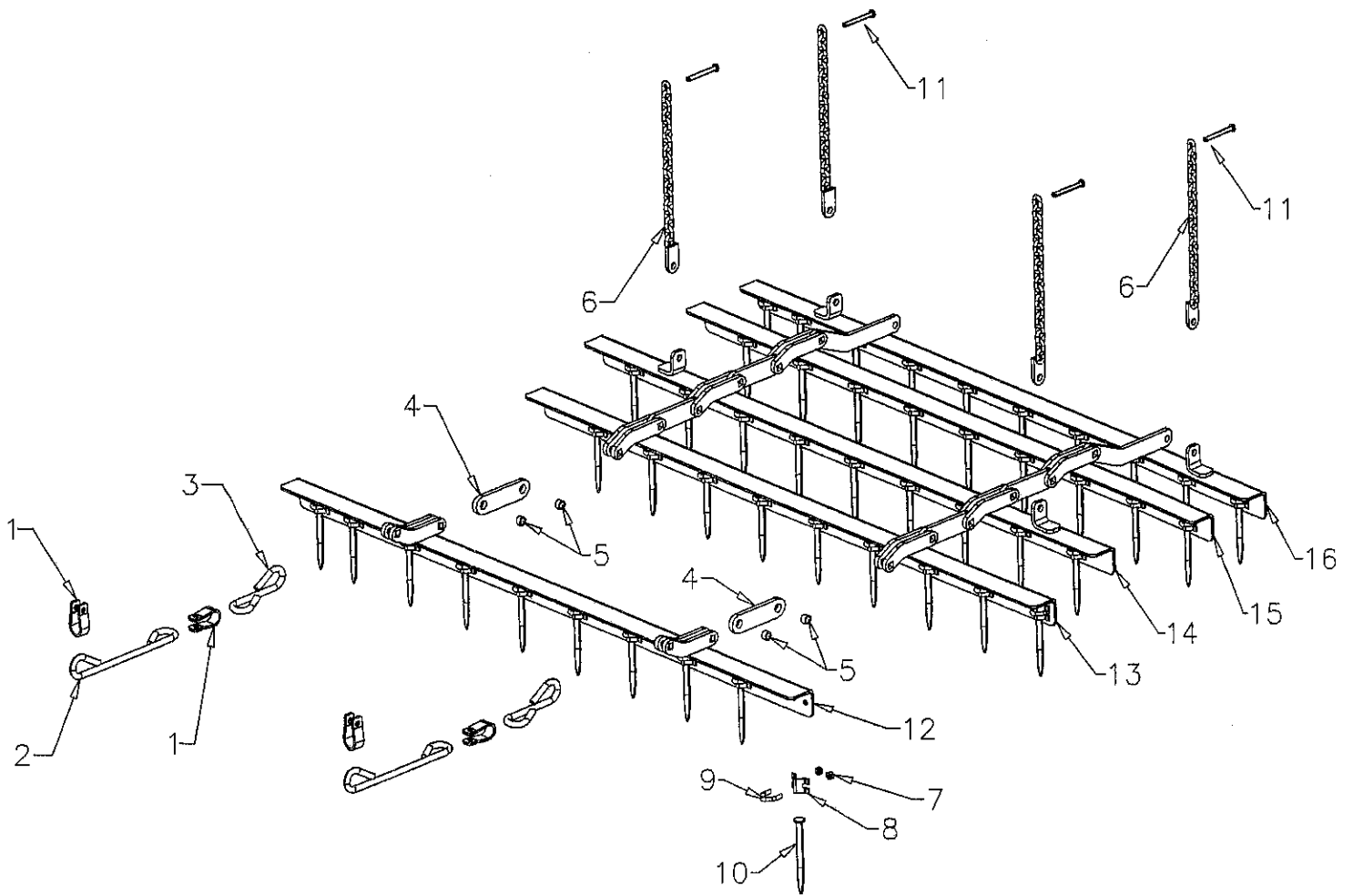

Offset Gauge Wheel		
REF#	DESCRIPTION	PART NUMBER
1	U-Bolt, 3/4" x 7" x 7" Sq.	8420
2	Bracket, HD Gauge Wheel	4507
3	Jack, Turnbuckle	8450
4	Bracket, Offset Gauge Wheel RH	2741
*	Bracket, Offset Gauge Wheel LH	2742
5	Hub, Gauge Wheel	9032
6	Wheel, 15" x 5" - 5 Hole / Less Tire	9041

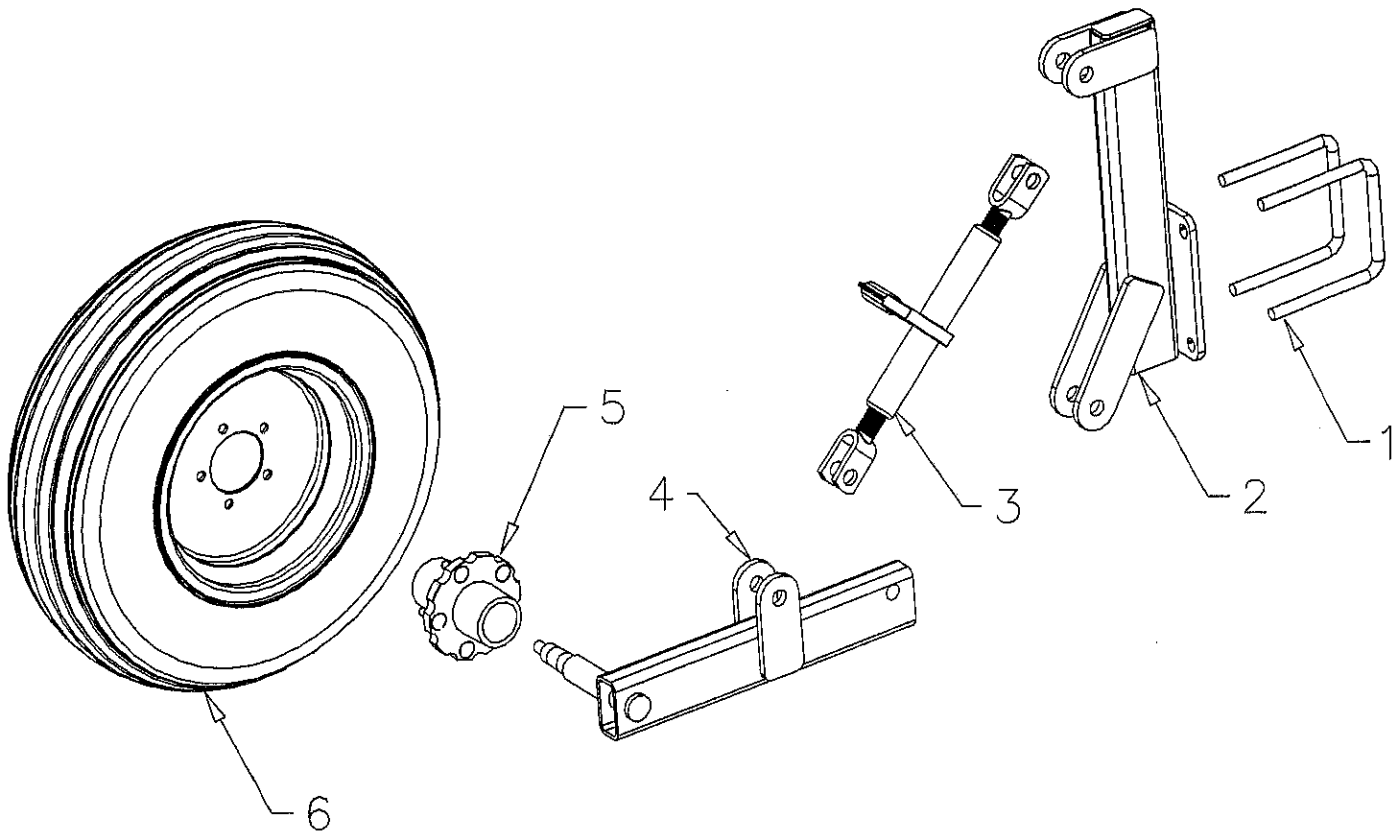

HYDRAULIC HOSE		
REF#	DESCRIPTION	PART NUMBER
1	Hose, 60"	9659
2	Hose, 100"	5HOS100
3	Hose, 83"	5HOS83
4	3/8" to 1/2" 90 Degree Elbow	9423
5	Tee, 3/8" Bulkhead	9373

